

THE INFLUENCE OF SOCIAL ACCESS AND ACCESS TO PUBLIC FACILITIES CHANGES IN CONSUMPTION PATTERNS

Mitra Musika Lubis¹, Bakti Darma², Rahmanta³, Ayu Sri Fajar⁴

¹Program Studi Ilmu Pertanian, Pascasarjana, Universitas Sumatera Utara

²Program Studi Agribisnis, Universitas Medan Area

³Departemen Agroteknologi, Fakultas Pertanian, Universitas Sumatra Utara

⁴Departemen Agribisnis, Fakultas Pertanian, Universitas Sumatra Utara

E-mail: mitra@staff.uma.ac.id

Abstract

The vast territory of Indonesia makes Indonesia rich in various foods. However, the irony is that the distribution of staple foods such as rice does not fully reach remote areas in Indonesia. This resulted in rice prices soaring and difficult to obtain. People don't care and try to switch to rice substitute foods such as bread, noodles, corn and other foods. This study aims to determine what factors influence the change in food habits from rice to non-rice. The research was conducted in Tanjung Pasir Village, Sei Merah Village, Lubuk Kertang Village, which is in Pangkalan Susu District, Langkat Regency, North Sumatra. The research model used is a descriptive quantitative research model. The data analysis used was Structural Equation Modeling (SEM) analysis assisted by AMOS 20.0 software. The data collection instrument used was a questionnaire instrument. The results of this study indicate that the factors of social access and public facilities influence changes in people's consumption patterns towards non-rice foods. The conclusion is that people in this area are experiencing diversification, changing consumption patterns to non-rice foods. The community prefers to look for food, especially for breakfast, to the stalls to look for non-rice foods such as bread, instant noodles, some corn and cassava. The reasons are: 1) The education factor can change people's food habits because it has an impact on the difficulty of getting a decent job, the quality of life is below standard, one of which is the difficulty to get rice; 2) The location of the market which is far away and difficult to access has resulted in soaring rice prices and this is one of the problems with public facilities; 3) The natural condition of the coast which lacks the availability of clean water and also poor sanitation makes it difficult for housewives to cook food at home.

Keywords: *Social Aspects, Consumption, Rice Food*

1. INTRODUCTION

Food security in the era of the Covid-19 pandemic is experiencing a difficult ordeal. Termination of Employment (PHK) occurs everywhere resulting in the activities of citizens as consumers becoming sluggish, which also has an impact on the decline in the performance of producers, one of which is in vital sectors such as food. One of the causes is the soaring price of raw materials and efforts to hire employees (Rohman & Andadari, 2021). Even though the role of food is very important which will determine the level of health, especially the fulfillment of nutrition and human nutrition. Communities can live healthily and can carry out activities to fulfill the needs of daily life.

Problems regarding food are usually caused by people not being able to obtain sources of food production such as water, land, capital and technology (Warsilah, 2013). If the problem of food shortages continues in an area for a long time, it will result in changing consumption patterns (food habits). Food habits is a habit of consuming food that occurs repeatedly (Khumaidi in Ridwan, 2019). Food habits can be formed by several factors such as food scarcity due to prolonged

THE INFLUENCE OF SOCIAL ACCESS AND ACCESS TO PUBLIC FACILITIES CHANGES IN CONSUMPTION PATTERNS

Mitra Musika Lubis, Bakti Darma, Rahmanta, Ayu Sri Fajar

conflicts or natural disasters which result in the availability of food (which is commonly eaten) depleting and being replaced with new food. Changes in Foodhabits will refer to both positive and negative things. Changes in food habits towards a positive direction, namely the habit of eating healthy and nutritious foods. The changes in food habits are in a negative direction, namely changes in the habit of consuming unhealthy foods. There are several characteristics that food should have when changing food habits, namely switching to foods that have a high enough energy and protein content (Christiaensen in Umanailo, 2019).

In the case determined in the area of North Sumatra. There has been a change in the pattern of consumption of its citizens due to difficulties in obtaining several types of food. The impact can lead to new habits such as changes in consumption patterns of people who no longer provide breakfast but prefer to buy breakfast at the shop. The reason is because in the village there are many facilities such as stalls selling various breakfast menu foods. The condition of the area being close to the coast makes it impossible for vegetable farmers to grow vegetables in the highlands, only mangrove forests grow in coastal areas. This condition is exacerbated by the distance from the village market to the sub-district market which is quite far, about 15 minutes (motorcycle). Long travel time due to bad road conditions. The schedule for operating the village market is only once a week, namely on Tuesday morning. Far from the market, around the residential areas there are approximately 38 stalls selling various breakfast menus. Of the 38 stalls, one of them is a tofu and tempe craftsman.

Apart from the scarcity of food, it is suspected that there is a cultural influence in that village where the majority of the Banjar people (80%) have a habit of liking consumption patterns by sitting in a shop drinking coffee in the morning, the mothers buy breakfast then bring food it returns home.

Based on the problems above, related to changes in Foodhabist, it can be traced to what factors are influencing it. The hypotheses of this study are: 1) factors of social access to rice food access; 2) Factors of public facilities and others on the absorption of rice food; 3) social access and increased access to facilities will lead to changes in consumption patterns towards non-rice food.

2. RESEARCH METHOD

This research was conducted in Tanjung Pasir Village, Sei Merah Village, Lubuk Kertang Village, which is in Pangkalan Susu District, Langkat Regency, North Sumatra. The population in this study includes all residents of the three villages, approximately 100 heads of households. The sample in this study uses the following formula (Devita, 2018):

$$n_o = \frac{Z^2 \cdot p \cdot (1-p)}{d^2}$$

Information:

n = minimum number of samples required

p = proportion of residents studied as many as 25 heads of households

q = 1-p (proportion of residents surveyed as many as 25 heads of households)

d = limit of error or absolute precision

if set = 0.05 or $Z_{1 - /2} = 1.96$ or Z_2

This formula is used because the total population is not known with certainty. Based on this formula, it is obtained – $n = [(1.96)(0.25)(0.75)/0.0025]= 147$ so that the number of samples in this study amounted to 147 respondents.

The method in this study uses a type of descriptive quantitative method. The exogenous variables in this study are social access and public facilities, while the endogenous variables are access to rice food, absorption of rice food and also changes in consumption patterns. The factors of the five exogenous and endogenous variables can be seen in Figure 1.

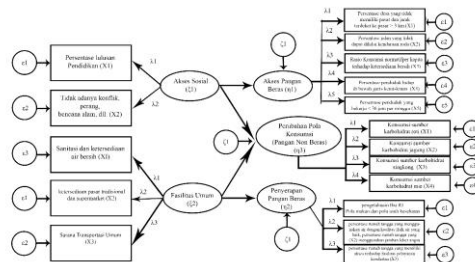

Figure 1: Factors of Exogenous and Endogenous Research Variables

The data collection technique used was a questionnaire technique which was distributed to the research sample respondents. The questionnaire used is based on 5 indicators, namely the rice food access questionnaire with five indicators, the rice food absorption questionnaire with three indicators and the consumption pattern change questionnaire with four indicators.

The data analysis technique used is inferential data analysis technique using Structural Equation Modeling (SEM) analysis assisted by AMOS 20.0 software.

3. RESULTS AND DISCUSSION

3.1. Structural Equation Model (SEM) Test

Goodness of Fit (GOF) Model Test Results

The GOF test according to Ghazali in Lidiawati (2021), the GOF test is intended to assess the accuracy of the sample regression function in estimating actual values. According to Nattino et al., (2020) the GOF test has four related approaches to assessing the GOF model, namely linear regression of the observed value versus the predicted value, the number of squared prediction errors, a reliability index that summarizes the prediction as a Ks factor of the observed value, and a measure of fitness such as correlation that normalizes the sum of the squared prediction errors to between zero and one.

Basically, the GOF measure consists of three main measures, namely absolute fit tests, comparative (incremental fit measures) and parsimony (parsimonius fit measures). The value indicators of the three GOF measures and their results can be seen in table 1.

THE INFLUENCE OF SOCIAL ACCESS AND ACCESS TO PUBLIC FACILITIES CHANGES IN CONSUMPTION PATTERNS

Mitra Musika Lubis, Bakti Darma, Rahmanta, Ayu Sri Fajar

Table 1. Structural Equation Model (SEM) Feasibility Test Results

Goodness of Fit Index		Cut-off values	Results
<i>Absolute Fit Test</i>	Chi-Square		105,851
	probability	≥ 0.05	0.351
	GFI	≥ 0.90	0.891
	RMSEA	≤ 0.08	0.022
<i>Incremental Fit Measures</i>	AGFI	≥ 0.90	0.835
	NFIs	≥ 0.90	0.761
	CFI	≥ 0.95	0.984
	IFI	≥ 0.95	0.986
<i>Parsimonius Fit Measures</i>	PNFI	≥ 0.95	0.979
CMIN/DF		< 2	1,048

Based on the results of testing the 10 GOF Model measurement indicators, there were only three indicators that did not meet the minimum criteria, namely the GFI, AGFI, and also NFI indicators. However, several indicators representing the three main measurements (AFT, IFM, and PFM) GOF model test score above the minimum criteria so that the conclusion is said to be fit (a value greater/smaller than the Cut-off value).

3.2.Hypothesis test

The results of this research hypothesis test based on the hypothesis that has been formulated previously can be seen in the structural equation model table below.

Table 2. Hypothesis Testing

	Estimates	SE	Std Est	CR	P	Cut-off values
APB <--- US	2.157	0.903	0.50	2,318	0.017	< 0.05
PPK <--- US	1,311	0.284	0.67	4,745	***	< 0.05
PPK <--- FU	1.354	0.298	0.66	4,707	***	< 0.05
PPB <--- FU	16,511	32,618	1.48	0.536	0.592	< 0.05

Information:

- US = Social Access
- FU = Public Facilities
- APB = Access to Rice Food
- PPB = Absorption of Rice Food
- PKK = Changes in Consumption Patterns

Based on the table data above, it shows that Social Access has a significant influence on Access to Rice Food with a probability value of 0.017 <0.05, which means that Ha is accepted. Social access has a significant effect on changes in consumption patterns with a probability value of 0.000 <0.05, which means that Ha is accepted. Public facilities have a significant influence on changes in consumption patterns with a probability value of 0.000 <0.05, which means that Ha is accepted. Public facilities have no significant effect on rice food absorption with a probability value of 0.592 <0.05, which means that H0 is accepted.

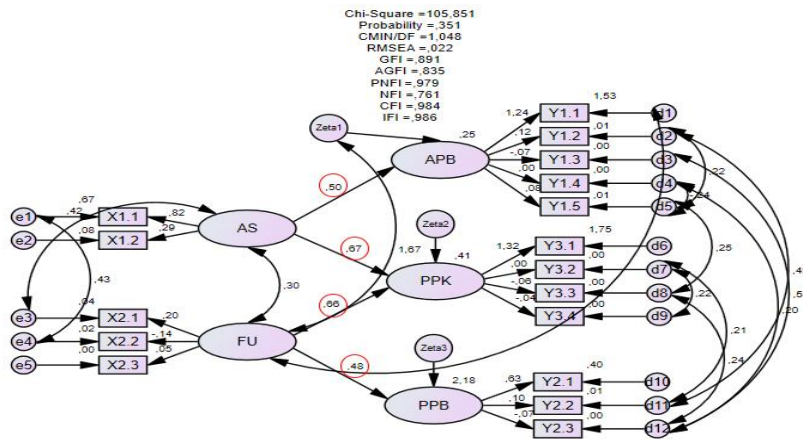

Figure 2. Structural Equation Model (SEM) Test Results

3.3. Social access to rice food access

Food scarcity can cause the food habits of the people of a region to change. These changes can be viewed from various variables and their factors. Social access has a significant influence on rice food access. Based on the picture above, the probability value is 0.017 which is lower than 0.05. In addition, the value of the loading factor for Social Access (AS) to Access to Rice Food (APB) obtained is a positive value of 0.50.

If we review the factors that contribute to AS, then the education factor (X1.1) contributes more (factor loading value = 0.82) compared to other factors, namely the factor of conflict, natural disasters or war (X1.2) (value loading factor = 0.29) in influencing APB. So it can be concluded that the majority of residents who only graduated from elementary or junior high school made them work with low incomes which prevented them from making rice as a staple food.

The factor most influenced by AS on APB is the percentage of villages that do not have markets and the distance to markets is relatively far (Y1.1) (factor loading value = 1.24). Residents cannot afford to buy rice because the location of the traditional market in the village is quite far away and access roads are damaged, making it difficult to find. If only we could get the rice, when it was traded again in the village, the price would skyrocket because of added transportation costs. As a result, many local villagers prefer to look for staple foods to replace rice at the stalls. This phenomenon is the same as the supporting factors for changing food habits from consuming large-based foods to non-rice foods proposed by Wahyuningdyah et al,

3.4. General Facilities for Rice Food Absorption

Public facilities (FU) have no significant effect on rice food absorption (PPB) with a probability value of 0.592 or higher than 0.05. The loading factor value obtained is positive at 0.48.

The FU factors on PPB are relatively low. The factors that contributed to the highest FU were sanitation and the availability of clean water (X2.1) (factor loading value 0.20).

The factor most influenced by FU on PPB was the knowledge of housewives on diet and health care (Y2.1) (factor loading value 0.63). It can be concluded that water is very beneficial for human life, especially in the household. Water can be used for daily needs such as for bathing, cooking, washing, drinking and other activities. Poor water sanitation results in poor water quality as well so that water is not suitable for cooking, especially cooking rice or cooking other dishes at home. This is a natural phenomenon for people who live in coastal areas. The main problems of the

THE INFLUENCE OF SOCIAL ACCESS AND ACCESS TO PUBLIC FACILITIES CHANGES IN CONSUMPTION PATTERNS

Mitra Musika Lubis, Bakti Darma, Rahmanta, Ayu Sri Fajar

Indonesian people in coastal areas in general are still focused on adequate housing, clean water supply, family latrines,

3.5.Social Access to Changes in Consumption

Social Access (AS) has a significant influence on Changes in Consumption Patterns (PPK) with a probability value of 0.000 or lower than 0.05. The loading factor obtained has a positive value of 0.67. Likewise Public Facilities (FU) have a significant influence on Changes in Consumption Patterns (PPK) with a probability value of 0.000 or lower than 0.05. The loading factor obtained has a positive value of 0.66.

Of the two exogenous variables (social access and public facilities) the factors that have a strong influence are education and the availability of clean water that is inadequate due to poor sanitation has an influence on changes in consumption patterns of residents. Locals prefer to buy non-rice fast food at warungs. When viewed from the factor of changing consumption patterns, the biggest change is consuming carbohydrates such as bread (factor loading value of 1.75). The reason is because bread is a practical food, inexpensive, filling and has many flavors so that people don't get bored eating bread. Apart from bread, non-rice staple foods favored by local residents are noodles, corn, cassava and other foods. The practicality of bread compared to other non-rice foods does not require water to serve it. In contrast to noodles, corn or cassava which need to be boiled first using water. Meanwhile, the local village is experiencing scarcity of clean water due to poor water sanitation. Plus, in coastal areas, corn and cassava farmers are very rare, so they are still in the category of food which is quite rare in this area. The majority of coastal communities have livelihoods as fishing (fishermen) or other marine products Plus, in coastal areas, corn and cassava farmers are very rare, so they are still in the category of food which is quite rare in this area. The majority of coastal communities have livelihoods as fishing (fishermen) or other marine products Plus, in coastal areas, corn and cassava farmers are very rare, so they are still in the category of food which is quite rare in this area. The majority of coastal communities have livelihoods as fishing (fishermen) or other marine products(Hajar et al., 2018).

The scarcity of rice does not mean completely abandoning rice as the main food and a characteristic of the staple food of Indonesian society. Indeed, past policies relied heavily on rice. However, relying on one type of food is clearly unhealthy and cannot support sustainability for agriculture in Indonesia(Gardjito et al., 2018). "Mixed" food habits should be encouraged to remain part of the culture. This term is known as food diversification or a program that aims so that people are not fixated on consuming only one type of staple food and try to consume other foodstuffs as well.(Ningrum & Kurniawan, 2019). Implementation of diversification of food consumption towards consuming food that is varied, has high nutritional value, is balanced and safe will provide great benefits. Moreover, if the government works together with the community in exploring and developing the potential of local food sources(Rahajeng & Khotimah, 2020). In coastal areas fish commodities are very abundant. Consumption of fish is the main food for residents because they consume it every day. The habit of the people here eating fish is the same as the consumption of tofu and tempeh side dishes in Java. Another effort that can be used as a mixed ingredient is by trying to cultivate non-rice foods such as tubers, various kinds of bananas, nuts and other foods. This food is not only needed by coastal communities but can also be consumed by people in island villages (Warsilah, 2013).

4. CONCLUSION

For coastal communities in Pangkalan Susu District, North Sumatra, the educational factor can change people's food habits due to economic limitations, making it difficult to get rice. Inadequate public facilities, such as market locations that are far away and difficult to access, have caused rice prices to soar. In addition, the conditions in this area, which is a coastal area, have problems with the availability of clean water and poor sanitation, which results in difficulties for housewives when they want to cook food at home. Conditions like this have resulted in people in the oni area choosing to look for food, especially breakfast, to shop. The food menu provided at the stall is non-rice food such as rot, instant noodles, some corn and cassava.

REFERENCES

- Ayani, D. (2021). Rice Price Control Instruments in Indonesia: Effective Time Required. *JOURNAL OF FOOD*, 30(2), 75-86.
- Bustani, B., Khaddafi, M. ., & Nur Ilham, R. (2022). REGIONAL FINANCIAL MANAGEMENT SYSTEM OF REGENCY/CITY REGIONAL ORIGINAL INCOME IN ACEH PROVINCE PERIOD YEAR 2016-2020. *International Journal of Educational Review, Law And Social Sciences (IJERLAS)*, 2(3), 459–468. <https://doi.org/10.54443/ijerlas.v2i3.277>
- Devita, EM (2018). The Influence of Country Of Origin And Brand Image To Purchase Decision Of South Korean Cosmetic Brand Etude House. UNIKA Soegijapranata Semarang.
- Falahuddin, F., Fuadi, . F., Munandar, M., Juanda, R. ., & Nur Ilham, R. . (2022). INCREASING BUSINESS SUPPORTING CAPACITY IN MSMES BUSINESS GROUP TEMPE BUNGONG NANGGROE KERUPUK IN SYAMTALIRA ARON DISTRICT, UTARA ACEH REGENCY. *IRPITAGE JOURNAL*, 2(2), 65–68. <https://doi.org/10.54443/irpitage.v2i2.313>
- Geovani, I. ., Nurkhotijah, S. ., Kurniawan, H. ., Milanie, F., & Nur Ilham, R. . (2021). JURIDICAL ANALYSIS OF VICTIMS OF THE ECONOMIC EXPLOITATION OF CHILDREN UNDER THE AGE TO REALIZE LEGAL PROTECTION FROM HUMAN RIGHTS ASPECTS: RESEARCH STUDY AT THE OFFICE OF SOCIAL AND COMMUNITY EMPOWERMENT IN BATAM CITY. *International Journal of Educational Review, Law And Social Sciences (IJERLAS)*, 1(1), 45–52. <https://doi.org/10.54443/ijerlas.v1i1.10>
- Gardjito, M, Djuwardi, A., & Harmayani, E. (2018). Pangan Nusantara: Characteristics and prospects for accelerating food diversification. *Prenada Median*.
- Hajar, D., Nurliani, N., & Hasan, I. (2018). Household Food Security Based on Quality of Food Consumption and Factors Affecting It. *Wiratani*, i(2).
- Ilham, Rico Nur. et all (2019). Investigation of the Bitcoin Effects on the Country Revenues via Virtual Tax Transactions for Purchasing Management. *International Journal of Supply Management*. Volume 8 No. 6 December 2019.
- Ilham, Rico Nur. et all (2019).. Comparative of the Supply Chain and Block Chains to Increase the Country Revenues via Virtual Tax Transactions and Replacing Futures of Money. *International Journal of Supply Management*. Volume 8 No. 5 August 2019.
- Lasta Irawan, A. ., Briggs, D. ., Muhammad Azami, T. ., & Nurfaliza, N. (2021). THE EFFECT OF POSITION PROMOTION ON EMPLOYEE SATISFACTION WITH COMPENSATION AS INTERVENING VARIABLES: (Case Study on Harvesting Employees of PT. Karya Hevea Indonesia). *International Journal of Social Science*,

THE INFLUENCE OF SOCIAL ACCESS AND ACCESS TO PUBLIC FACILITIES CHANGES IN CONSUMPTION PATTERNS

Mitra Musika Lubis, Bakti Darma, Rahmanta, Ayu Sri Fajar

- Educational, Economics, Agriculture Research, and Technology (IJSET), 1(1), 11–20.<https://doi.org/10.54443/ijset.v1i1.2>
- likdanawati, likdanawati, Yanita, Y., Hamdiah, H., Nur Ilham, R., & Sinta, I. (2022). EFFECT OF ORGANIZATIONAL COMMITMENT, WORK MOTIVATION AND LEADERSHIP STYLE ON EMPLOYEE PERFORMANCE OF PT. ACEH DISTRIBUS INDO RAYA. International Journal of Social Science, Educational, Economics, Agriculture Research, and Technology (IJSET), 1(8), 377–382.<https://doi.org/10.54443/ijset.v1i8.41>
- LIDIAWATI, L. (2021). Analysis of the Influence of Price and Service Quality on Consumer Decisions in Indonesia Points at Syamsuddin Noor Airport. Kalimantan Islamic University MAB.
- Majied Sumatrani Saragih, M. ., Hikmah Saragih, U. ., & Nur Ilham, R. . (2021). RELATIONSHIP BETWEEN MOTIVATION AND EXTRINSIC MOTIVATION TO ICREASING ENTREPRENEURSHIP IMPLEMENTATION FROM SPP AL-FALAH GROUP AT BLOK 10 VILLAGE DOLOK MASIHUL. MORFAI JOURNAL, 1(1), 1–12.<https://doi.org/10.54443/morai.v1i1.11>
- Misdayanti, S. (2021). Description of Environmental Sanitation in the Coastal Communities of Bajo Indah Village. Affiliation: Journal of Public Health, 6(1), 19-29.
- Nattino, G., Pennell, ML, & Lemeshow, S. (2020). Assessing the goodness of fit of logistic regression models in large samples: A modification of the Hosmer-Lemeshow test. Biometrics, 76(2), 549-560.
- Ningrum, P. P. A., & Kurniawan, R. (2019). Analysis of Consumer Behavior and Non-Rice Food Potential Based on Household Characteristics in Tungkal Jaya District, Musi Banyuasin Regency. Societa: Journal of Agribusiness Sciences, 7(2), 91-103.
- NURMALA RIDWAN, A. (2019). The Relationship between Food Habits and Nutritional Status in Young Girls at Cokroaminoto Sukaresmi Senior High School, Cianjur Regency in 2019.
- Nur Ilham, R. ., Arliansyah, A., Juanda, R., Multazam, M. ., & Saifanur, A. . (2021). RELATHIONSIP BETWEEN MONEY VELOCITY AND INFLATION TO INCREASING STOCK INVESTMENT RETURN: EFFECTIVE STRATEGIC BY JAKARTA AUTOMATED TRADING SYSTEM NEXT GENERATION (JATS-NG) PLATFORM. International Journal of Economic, Business, Accounting, Agriculture Management and Sharia Administration (IJEBAS), 1(1), 87–92.<https://doi.org/10.54443/ijebas.v1i1.27>
- Nur Ilham, R., Heikal, M. ., Khaddafi, M. ., F, F., Ichsan, I, F, F., Abbas, D. ., Fauzul Hakim Hasibuan, A. ., Munandar, M ., & Chalirafi, C. (2021). Survey of Leading Commodities Of Aceh Province As Academic Effort To Join And Build The Country. IRPITAGE JOURNAL, 1(1), 13–18.<https://doi.org/10.54443/irpitage.v1i1.19>
- Nur Ilham, R., Likdanawati, L., Hamdiah, H., Adnan, A., & Sinta, I. . (2022). COMMUNITY SERVICE ACTIVITIES “SOCIALIZATION AVOID STUDY INVESTMENT” TO THE STUDENT BOND OF SERDANG BEDAGAI. IRPITAGE JOURNAL, 2(2), 61–64.<https://doi.org/10.54443/irpitage.v2i2.312>
- Nur Ilham, R., Arliansyah, A., Juanda, R. ., Sinta, I. ., Multazam, M. ., & Syahputri, L. . (2022). APPLICATION OF GOOD CORPORATE GOVERNANCE PRINCIPLES IN IMPROVING BENEFITS OF STATE-OWNED ENTERPRISES (An Emperical Evidence from Indonesian Stock Exchange at the Moment of Covid-19). International Journal of Economic, Business, Accounting, Agriculture Management and Sharia Administration (IJEBAS), 2(5), 761–772.<https://doi.org/10.54443/ijebas.v2i5.410>
- Nur Ilham, R., Likdanawati, L., Hamdiah, H., Adnan, A., & Sinta, I. . (2022). COMMUNITY SERVICE ACTIVITIES “SOCIALIZATION AVOID STUDY INVESTMENT” TO THE STUDENT BOND OF SERDANG BEDAGAI. IRPITAGE JOURNAL, 2(2), 61–64.<https://doi.org/10.54443/irpitage.v2i2.312>

- Rahmaniar, R., Subhan, S., Saharuddin, S., Nur Ilham, R. ., & Anwar, K. . (2022). THE INFLUENCE OF ENTREPRENEURSHIP ASPECTS ON THE SUCCESS OF THE CHIPS INDUSTRY IN MATANG GLUMPANG DUA AND PANTON PUMP. *International Journal of Social Science, Educational, Economics, Agriculture Research, and Technology (IJSET)*, 1(7), 337–348. <https://doi.org/10.54443/ijset.v1i7.36>
- Rico Nur Ilham, Irada Sinta, & Mangasi Sinurat. (2022). THE EFFECT OF TECHNICAL ANALYSIS ON CRYPTOCURRENCY INVESTMENT RETURNS WITH THE 5 (FIVE) HIGHEST MARKET CAPITALIZATIONS IN INDONESIA. *Journal of Economics*, 11(02), 1022–1035. Retrieved from <http://ejournal.seaninstitute.or.id/index.php/Ekonomi/article/view/481>
- Rahajeng, GY, & Khotimah, K. (2020). Diversification of Food Consumers Based on Local Potential in Tarakan City. *Journal of Borneo Saintek*, 3(2), 61-72.
- Rohman, LL, & Andadadri, RK (2021). The Impact of the COVID-19 Pandemic on Household Businesses and Survival Strategies. *Journal of Research and Development of Science and Humanities*, 5(1), 82-90.
- Rosnita, R. (2014). The al-Wasliyah Education Movement in North Sumatra. *Ulumuna*, 18(1), 59-80.
- Sandi, H. ., Afni Yunita, N. ., Heikal, M. ., Nur Ilham, R. ., & Sinta, I. . (2021). RELATIONSHIP BETWEEN BUDGET PARTICIPATION, JOB CHARACTERISTICS, EMOTIONAL INTELLIGENCE AND WORK MOTIVATION AS MEDIATOR VARIABLES TO STRENGTHENING USER POWER PERFORMANCE: AN EMPERICAL EVIDENCE FROM INDONESIA GOVERNMENT. *MORFAI JOURNAL*, 1(1), 36–48. <https://doi.org/10.54443/morai.v1i1.14>
- Sinta, I. ., Nur Ilham, R., Kumala Sari, D. ., M, M., Khaidir, K., & Ekamaida, E. (2021). Training The Processing Of Tomato Sauce For A Home-Based Business The Scale Of SMES. *IRPITAGE JOURNAL*, 1(1), 26–28. <https://doi.org/10.54443/irpitage.v1i1.24>
- Sinurat, M. ., Heikal, M. ., Simanjuntak, A. ., Siahaan, R. ., & Nur Ilham, R. . (2021). PRODUCT QUALITY ON CONSUMER PURCHASE INTEREST WITH CUSTOMER SATISFACTION AS A VARIABLE INTERVENING IN BLACK ONLINE STORE HIGH CLICK MARKET: Case Study on Customers of the Tebing Tinggi Black Market Online Store. *MORFAI JOURNAL*, 1(1), 13–21. <https://doi.org/10.54443/morai.v1i1.12>
- Umanailo, MCB (2019). Diversification of Local Public Consumption. *Journal of AGRISEP: Study of Socio-Economic Problems in Agriculture and Agribusiness*, 18(1), 61-74.
- Wahyuningdyah, RY, Susilowati, MGWK, & Kurniasari, W. (nd). Community Intentions To Switch To Non-Rice Food Consumption Patterns.
- Wijoyo, BHR (2022). Food Security in the Perspective of Rice Availability in East Java. *UPN” veterans' East Java*.
- Yusuf Iis, E., Wahyuddin, W., Thoyib, A., Nur Ilham, R., & Sinta, I. (2022). THE EFFECT OF CAREER DEVELOPMENT AND WORK ENVIRONMENT ON EMPLOYEE PERFORMANCE WITH WORK MOTIVATION AS INTERVENING VARIABLE AT THE OFFICE OF AGRICULTURE AND LIVESTOCK IN ACEH. *International Journal of Economic, Business, Accounting, Agriculture Management and Sharia Administration (IJEBAAS)*, 2(2), 227–236. <https://doi.org/10.54443/ijeabas.v2i2.191>